



WOOD CHIPPER HV106 USER MANUAL



P. de Heus en Zonen Greup B.V.
Stougjesdijk 153
3271 KB Mijnsheerenland
The Netherlands
Tel: +31 (0) 18 66 12 333
E-mail: info@boxeragri.nl



EN | ENGLISH

TRANSLATION OF THE ORIGINAL MANUAL

CONTENT

1.	INTRODUCTION	4
2.	SAFETY	5
2.1	Safety symbol	5
2.2	Safety instructions.....	6
2.3	Safety guidelines	7
2.4	Safety decals.....	8
2.4.1	Safety decal place	8
2.5	Preparation.....	11
2.6	Safe maintenance.....	11
2.6.1	Maintenance intervals	12
2.7	Operational safety.....	13
2.8	Hydraulic safety.....	14
2.9	Storage safety.....	14
2.10	Transport safety	14
3.	INSTALLATION	15
4.	OPERATIONAL SAFETY	23
4.1	For the new user or owner.....	24
4.2	First use	24
4.3	Checklist before use	24
4.4	Length of the power take-off	25
4.5	Machine commissioning.....	26
4.6	Transport.....	32
5.	SPECIFICATIONS	33
5.1	Torque	33
5.2	Torque for hydraulic fittings.....	35
6.	TROUBLESHOOTING	36
7.	CE DECLARATION OF CONFORMITY	37

1. INTRODUCTION

Congratulations with your choice of a 3-point wood chipper to carry out your work. This machine has been designed and manufactured to meet the requirements of the demanding wood and landscape industries.

A safe, efficient and problem-free operation of your wood chipper requires that you and everybody who uses or maintains the wood chipper reads and understands the safety, operation, maintenance and troubleshooting information in this operating manual.

This manual discusses the 3-point wood chipper HV106. Use the table of contents as a guideline to find the required information.

Keep this manual close so that you can frequently refer to it and to pass it onto new users or owners.

ATTENTION: The left, right, forwards and revers as specified in this manual are determined when you are sitting in the driver's seat of the tractor and you are looking towards the driving direction.

2. SAFETY

2.1 Safety symbol



This safety symbol means: CAUTION! ATTENTION IMPORTANT FOR YOUR SAFETY!
The safety symbol highlights important safety messages on the Boxer wood chipper and in the manual. If you see this symbol, take the possibility of physical injury or death into account. Observe the instructions given in the safety message.

- Accidents can lead to injury or death.
- Accidents cost money.
- Accidents can be prevented.

PAY ATTENTION WORDS

Pay attention to the HAZARD, WARNING and ATTENTION words in the safety messages. The suitable pay attention word for each message was selected based on the following guidelines:

HAZARD – Indicates an immediate dangerous situation that can lead to serious injury or death if not prevented. This pay attention word may only be used for the most extreme situations that usually occur in relation to machine parts that cannot be screened off due to functional reasons.

WARNING – Indicates a possible dangerous situation that can lead to serious injury or death if not prevented. This concerns, for example, hazards that people are exposed to when covers are removed. This may also be related to unsafe practices.

ATTENTION – Indicates a possible dangerous situation that can lead to slight or moderate injury or death if not prevented. This may also be related to unsafe practices.

2.2 Safety instructions

You are responsible for the safe operation and maintenance of your 3-point wood chipper. You must make sure you and everybody who uses, maintain or work with the wood chipper are aware of the procedures for use and maintenance and the related safety information in this manual.

This manual will guide you step-by-step through your working day and will tell you which safety instructions you must observe.

Make sure everybody that uses this machine is aware of the recommended use and maintenance procedures and observe all precautions. Most accidents can be prevented. If you ignore sound safety measures, you run the risk of being injured or, worse, death.

- Owners of the wood chipper must give operating instructions to users and/or employees before they are allowed to use the machine. These instructions must be repeated at least once a year.
- Safe use is of utmost importance. The user is responsible for reading, understanding and following ALL safety and operating instructions in the manual. Most accidents can be prevented.
- A person who has not read and understood all use and safety instructions is not qualified to use the machine. An untrained user exposes himself/herself and people around him/her to possible serious injury or death.
- Do not adjust the machine in anyway. An unauthorized modification may have a negative impact on its operation or safety and may influence the equipment's service life.
- Think in terms of Safety! Work Safely!
- Read and understand the manual and all safety messages before using, maintaining, changing or cleaning the 3-point wood chipper.
- A fire-extinguisher and first aid kit must be within arm's reach. Make sure people know how to use them.
- Do not allow anybody to hitch a ride on the machine.
- Use the suitable personal protective equipment. This list includes the following but is not limited to this:
 - A safety helmet
 - Safety shoes with anti-slip soles
 - Safety goggles or face shield
 - Work gloves
 - Protective clothing for all types of weather conditions
 - Hearing protection
 - Half face mask or dust mask
- Put all covers in place and make sure they are fastened properly before you start.
- Use suitable hearing protection if you are exposed long term to excessive noise.
- Switch off the machine and, next, switch off the engine of the tractor, remove the ignition key and put it in your pocket, engage the parking brake and wait until all moving parts have come to a complete standstill before performing maintenance, adjustment, repair or uncoupling activities.
- Make sure no people and certainly no small children are in the vicinity before you use the machine.
- Study the safety information on an annual basis with all staff who will use or maintain the wood chipper.



2.3 Safety guidelines

1. Strictly follow all safety instructions. Safety is everybody's responsibility. By following the recommended procedures, a safe working environment is offered to all users and bystanders. To prevent physical injury or death, you and those who work with you must follow the following precautions.
2. To provide a more complete picture, specific photos or figures in this manual may show a part regarding which the guard or protective cover has been removed. The machine may, however, never be used under those conditions. All protective covers and guards must be in their places. If a protective cover has been removed, it must be put back before the machine can again be used.
3. Replace all the illegible or missing safety or instruction signs. The locations where you can find such safety signs are indicated in this manual.
4. Never drink alcohol or take medication that may negatively affect your alertness or coordination when you use the machine. Consult your general practitioner if you take prescription medication.
5. Young children may never work with this machine. People may only use or install the machine if they have read this manual and correctly understand the operation and safety instructions. Study the safety instructions with all users on an annual basis.
6. This machine is dangerous for children and people who are not familiar with its operation. The user must be a responsible, correctly trained and physically capable person who is familiar with machines and trained in the use of this equipment. If elderly people are also working, physical impairments must be taken into consideration.
7. Never exceed the limits of a machine. If there are any doubts about whether the machine can tackle a job or can tackle it safely, do not try it.
8. Do not adjust the machine in anyway. Every unauthorized adjustment can result in serious injury or death and negatively impact the operation and service life of the equipment.
9. In addition to the design and configuration of this machine including the safety labels and facilities, limiting hazards and preventing accidents will depend on the awareness, carefulness and correct training of personnel who is involved in the operation, transport, maintenance and storage of the machine. See also the safety and use instructions in each of the relevant chapters of the motor and machine manuals. Pay careful attention to the safety signs on the tractor and the machine.

2.4 Safety decals

- Make sure all safety decals are clean and legible.
- Replace all damaged or missing decals.
- Replaced parts with safety decals must display the relevant safety decals.
- Item numbers can be found on the safety decals specified in chapter 3 on the right at the bottom. Use these item numbers when you order replacement parts.
- Safety decals can be obtained from your dealer or importer.

How to affix safety decals:

1. Make sure the place where you want to affix them is clean and dry.
2. Make sure the temperature is higher than 10 °C (50 °F).
3. Determine the exact place before removing the paper on the rear side.
4. Remove the smallest section of the paper on the rear side.
5. Keep the decal at the required place and carefully press on the smallest sticky part.
6. Remove the rest of the paper and careful smooth the rest of the decal until it is in the right place. Small air bubbles can be pricked with a needle and smoothed using a bit of the backing paper.

2.4.1 Safety decal place

The safety symbol types and their locations on the machine are shown in the following figures. Good safety requires that you become familiar with the various safety alerts and the warning type and area or a specific function related to that area where you need to bear safety in mind.

REMEMBER – If the safety alert is damaged, removed or illegible or parts have been replaced without safety alerts, new decals must be affixed. New safety decals can be obtained from your authorized dealer.

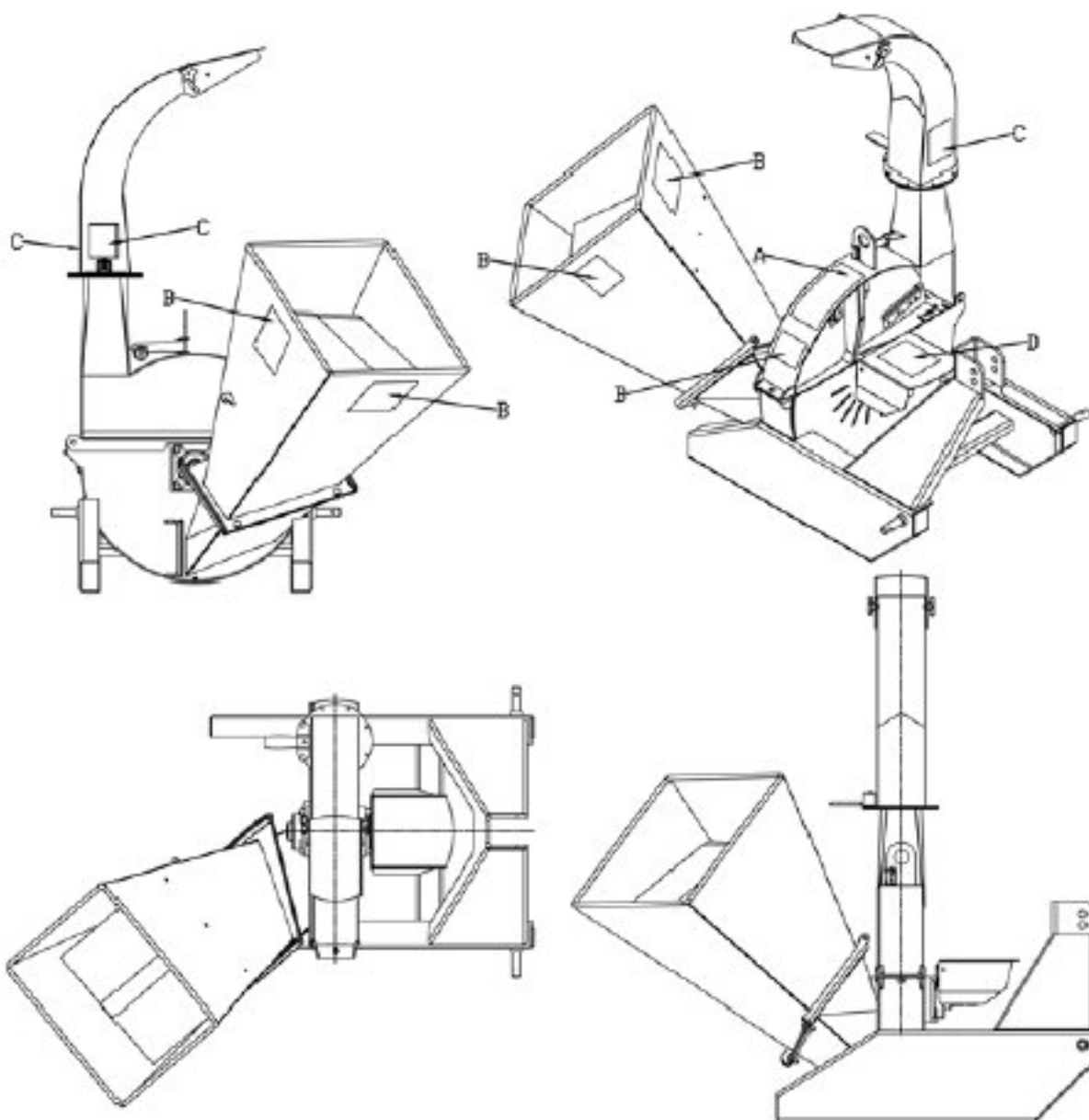

A

CAUTION

- Read and understand operator's manual before starting. Review safety instructions annually.
- Turn machine off, stop and disable engine, remove ignition key and place in your pocket, set park brake and wait for all moving parts to stop before adjusting, servicing, maintaining, repairing or unplugging.
- Keep the working area clean and free of debris to prevent slipping or tripping. Operate only on level ground.
- Close and secure rotor cover before operating.
- Close and secure all guards, deflectors and shields before starting and operating.
- Keep hydraulic lines and fittings tight, in good condition and free of leaks.
- Keep hands, feet, hair and clothing away from moving parts. Never wear loose clothing around machinery.
- Keep driveline universal joint angles equal and small as possible.
- Do not point discharge at people, animals or buildings. Rotor can expel wood chips fast enough to cause injury.
- Do not allow children, animals or unauthorized people into working area.
- Do not run machine inside a closed building to prevent asphyxiation from engine exhaust.
- Use care when feeding material into chipper. Do not send metal, bottles, cans, rocks, glass or other foreign material into wood chipper. If foreign material enters chipper, stop the machine, turn engine off and place ignition key in your pocket and wait for all moving parts to stop before removing material and/or unplugging. Inspect machine for damaged or loose parts before returning to work.
- Always wear P.P.E. (Personal Protective Equipment) such as safety goggles and heavy gloves whenever operating machine.
- Do not place hands or any body parts into feed hopper during operation.
- Do not move or transport chipper when the rotor is turning.
- Do not exceed a safe travel speed when transporting.

ZS400S

D

DANGER



THROWN OBJECT HAZARD

To prevent serious injury or death from thrown objects:

- Turn machine off, stop and disable engine, remove ignition key and place in your pocket, set park brake and wait for all moving parts to stop before adjusting, servicing, maintaining, repairing or unplugging.
- Do not direct discharge duct towards people, animals or property. Always wear appropriate safety gear. Keep hands and feet out of discharge openings.
- Keep others away.

ZS400

B

DANGER

ROTATING CUTTING BLADES



Keep heads and feet out of inlet and discharge openings while machine is operating to avoid serious personal injury. Stop engine, remove spark plug wire and allow machine to come to a complete stop before clearing obstructions or making adjustments.

ZS400

E

DANGER



ROTATING DRIVELINE HAZARD
KEEP AWAY

To prevent serious injury or death from rotating driveline:

- Keep all guards in place when operating.
- Operate only at 540 RPM.
- Keep hands, feet, hair and clothing away from moving parts.
- Keep U-joint angles equal and small as possible.
- Do not exceed driveline manufacturer's recommended operating length.

ZS4010

C

WARNING



HIGH PRESSURE FLUID HAZARD

To prevent serious injury or death from high-pressure fluid:

- Relieve pressure on system before repairing or adjusting.
- Wear proper hand and eye protection when searching for leaks. Use wood or cardboard instead of hands.
- Keep all components in good repair.

ZS400S

2.5 Preparation

1. Never commission the machine before you have read and fully understood this manual, the manual of the tractor and all safety messages and decals on the tractor and the machine.
2. Personal protective equipment including a safety helmet, safety goggles, safety shoes and gloves are recommended when mounting, installing, operating, adjusting maintaining, repairing, disassembling cleaning or moving the machine. Avoid long hair, loose clothing or jewelry in the vicinity of moving parts.
3. Long-term exposure to loud noise can lead to permanent hearing damage! Powerful machines with or without connected equipment will often be sufficiently loud to cause permanent or partial hearing loss.



We recommend using hearing protection since the noise from

the operating panel is higher than 80 dB. Noise higher than 85 dB can lead to hearing loss in the long term.

Noise levels of 90 dB or more may cause permanent and full hearing loss in the long term.

REMARK: Hearing loss due to loud noises (of tractors, chainsaws, radios and other similar sources near your ears) is cumulative during your life without a chance of being naturally restored.

4. Remove all obstacles that can become hooked on or become stuck in the work area since they may lead to injury or damage.
5. Only use the machine during daylight or in good artificial light.
6. Always check in advance whether the machine has been correctly mounted, has been adjusted and is in a good condition.
7. Make sure in advance that all safety protections and symbols have been installed correctly and are in good condition.

2.6 Safe maintenance

1. Good maintenance is your responsibility. Poor maintenance is inviting problems.
2. Keep the service area clean and dry.
3. Make sure power points and tools have been grounded in the correct manner.
4. Make sure there is always sufficient light.
5. Make sure there is sufficient ventilation. Never start an engine in a closed space. Exhaust gases may lead to suffocation.
6. Before you perform maintenance or installation work on the machine, switch off the engine, engage the brake and switch off the fuel supply.
7. Never work underneath the machine unless it is securely raised.
8. Always use personal protective equipment such as eye, hand and hearing protectors when performing service or maintenance work. Use heavy-duty or leather gloves when handling blades.
9. If replacement parts are required for regular maintenance and service, original factory parts must be used to make sure your machine meets the original specifications. The manufacturer cannot be held responsible for injury or damage caused by the use of non-approved parts and/or accessories.

10. A fire-extinguisher and first aid kit must be within arm's reach when performing maintenance and servicing the machine.
11. Tighten all bolts regularly. Also check regularly whether all electrical and fuel connections are fastened correctly.
12. When completing the maintenance or service work, make sure all safety protections and parts are installed before commissioning the machine.



2.6.1 Maintenance intervals

8 hour or daily

Lubricate the power take-off lubrication points.

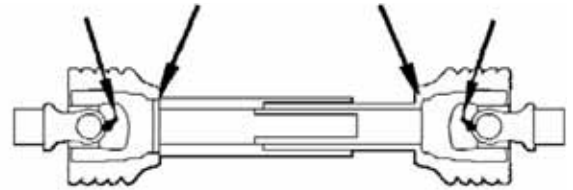

Power take-off lubrication points

40 hour or weekly

Lubricate the power take-off telescopic part.
Check the sharpness of the rotor/stationary blades.
Disassemble, sharpen or replace if required.



Telescopic part

100 hours

Lubricate the roller bearings.



Front rotor bearing



Rear rotor bearing

2.7 Operational safety

1. It is important that you read and observe the safety decals on the wood chipper. Clean or replace safety decals that are difficult to read or understand in view of your safety and that of others. You, the user, are responsible for the safe use of this machine.
2. Everything with moving parts may represent a hazard. A careful, safety-focused user who recognizes possible hazards and is committed to safety practices is best. The manufacturer has designed this wood chipper to be used with all safety facilities installed correctly to limit the chances of accidents occurring to a minimum. Read this manual to determine whether all safety facilities are present.
3. Close and fasten the rotor cover before using the machine.
4. Close and fasten all covers, deflectors and protection covers or guards before starting and using the machine.
5. Read and understand the manual before starting the machine. Study the safety instructions every year.
6. Personal protective equipment including a safety helmet, safety goggles, safety shoes and gloves are recommended when assembling, positioning, using, changing, maintaining, repairing, removing, cleaning or moving the machine. Avoid long hair, loose clothing or jewelry in the vicinity of moving parts.
7. Make sure hydraulic lines and fittings are fixed securely, in good condition and leak-free.
8. Keep limbs away from moving parts during the assembly, positioning, using, maintenance, repairing or moving or when removing obstructions.
9. Switch off the engine, stop and switch off the engine, take the key out of the ignition and put it in your pocket, engage the park brake and wait until all moving parts come to a standstill before performing maintenance, changes or repairs or removing obstructions.
10. Do not leave the machine running in a closed building to prevent suffocation by exhaust gases.
11. Be careful when you put material in the wood chipper. Do not insert metal, bottles, tins, stones, glass or other foreign material in the wood chipper. If material that should not be there ends in the wood chipper, you must stop the machine, switch off the engine, put the ignition key in your pocket and wait until all moving parts have stopped running before you remove any material and/or obstructions. Check the machine for damage or loose parts before resuming your work.
12. Never drink alcohol or take medication that may impede your alertness or coordination during the use of this machine. Consult your general practitioner if you take prescription medication.
13. Do not allow anybody to hitch a ride on the machine. There is no safe place for passengers.
14. Never allow children or unauthorized people to be around the machine or 'work' with it.
15. Never reach into the rotor or the openings of the feed hopper while the engine is running. Position the protective covers and guards and secure them in place before starting the engine.
16. Keep the workplace clean and free from waste to prevent stumbling. Only work on level ground.
17. Do not point the discharge hopper towards people, animals or buildings. The rotor can eject wood chips so fast that injury is caused.
18. Do not move or transport the wood chipper while the rotor is turning and the machine is operational.
19. Do not exceed the safe driving speed during transport.



2.8 Hydraulic safety

1. Make sure all parts of the hydraulic system are in good condition and clean.
2. Before you put the system under pressure, make sure all parts are fastened correctly and all lines, hoses and couplers are undamaged.
3. Do not try to repair lines, fittings or hoses provisionally using tape, clamps or binding agents. The hydraulic system works under extremely high pressure. Such repairs will break suddenly and will therefore lead to a dangerous and unsafe situation.
4. Use suitable hand and face protection when searching for a leak in the hydraulic system. Use a piece of wood or cardboard as a backstop instead of your hands to identify and isolate a leak.
5. If you are injured by a concentrated jet of hydraulic liquid under high pressure, you must immediately seek medical assistance. Hydraulic liquid that penetrates the skin may lead to an infection or a toxic reaction.
6. Remove the pressure from the hydraulic system before performing maintenance or work on the system.



2.9 Storage safety

1. Store the machine away from the vicinity of human activities.
2. Do not allow children to play on or around the stored machine.
3. Store the machine in a dry and flat location. Support the frame using, for example, wooden blocks if required.

2.10 Transport safety

1. Comply with all national, provincial and local legislation in relation to the safety and transport of machines on public roads.
2. Check whether all lights, reflectors and other lighting facilities are installed and in good working order.
3. Do not exceed a safe driving speed. Slow down on rough terrain and when taking bends.
4. Fold up the filling funnel before moving or transporting the wood chipper.
5. Make sure the machine has been fastened properly to the tractor and there is a locking pin through the mounting pins.
6. Do not drink alcohol if you have to drive.
7. Be a safe, thoughtful and considerate driver. Always give priority to oncoming vehicles under all conditions such as narrow bridges, intersections, etc. Pay careful attention to other road users.
8. Never transport people or animals on the machine.

3. INSTALLATION

The machine is delivered in transport configuration from the factory. Always use tools, equipment and forklift trucks with suitable dimensions and power for the installation. Always make sure there are two persons present to lift, move and assemble the machine.

When the machine is delivered, follow these instructions during the preparation:

1. Make sure there are no people, animals and especially children in the area.
2. Use a forklift truck to lift or move the pallet/machine. Keep the center of gravity near to the ground.
3. Move the machine to the location where you want to install the machine. Make sure there is sufficient space around the machine.
4. Cut through the fastening straps.
5. Lift the top part (feed hopper) and carefully move it to one side by using a forklift truck.



Transport fastening straps and crate



Lifting the feed hopper

6. Position the individual components next to the machine.
7. Remove the protective film/packaging from all components.



Gather all components

-
8. Remove the steel frame with an angle grinder.



Remove the steel frame

9. Use a forklift truck to hoist and lift the main component.



Lift the main component

10. Remove the pallet and place the machine on the floor.



Parts without a pallet and packaging

11. Remove both screws on the rear side of the feed hopper and the hopper for the main components.



Remove the screws from the feed hopper

-
12. Lift the feed hopper using a forklift truck and position it straight in front of the hopper for the main component.



Remove the screws from the hopper main component



Install the hopper

13. Fasten the feed hopper on both sides using the previously loosened screws.



Fasten the hopper using the screws

-
14. Loosen the three screws on the rotor housing (1x left, 2x right).



Loosen the screws

15. Position the protective cover on the rotor housing by using a forklift truck.

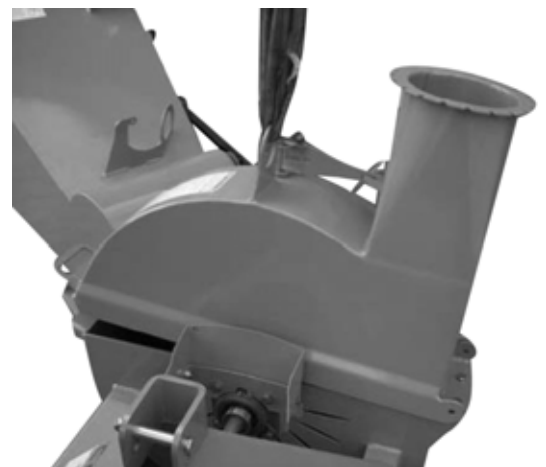

Position the protective cover

16. Fasten the protective cover using the previously loosened screws (3x).



Tighten the screws

17. Use both bottom screws of the 3-point linkage.



Use the bottom screws

18. Fasten the power take-off on the engine shaft of the wood chipper by loosening the locking pin, pushing the bracket over the shaft and pushing the bracket until the locking pin falls in place. It should be noted that the end with the shear pin is fastened to the machine's shaft.

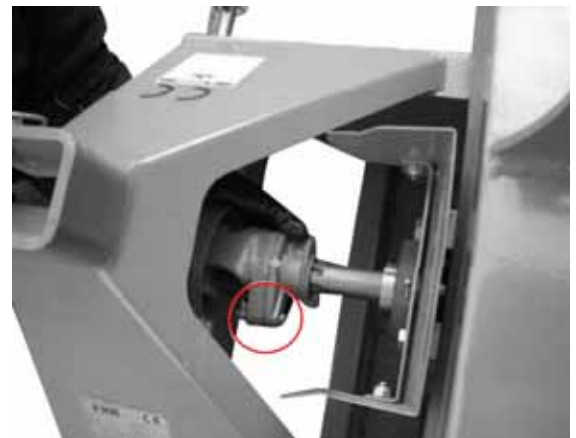

Assemble the power take-off

19. Fold down the protective cover for the power take-off.



Fold down the protective cover

-
20. To install the discharge hopper, first loosen all eight screws on the rear side of the hopper and remove the spacers.



Remove the spacers

21. Position the discharge hopper on the rotor housing.



Position the discharge hopper

-
22. Fasten the spacers under the mounting plate. First hold the narrow spacers and, next, position them under the wider one and screw them all to each other.



Position the spacers

23. Install the lever in alignment with the discharge hopper.



Assemble the lever

24. Loosen the chain on the discharge hopper so that it is suspended down in a straight line. Fold out the movable end piece of the discharge hopper that regulates the discharge range and clamps the spring.



Adjusting the discharge range

-
25. Fasten the chain to the hooks on the side of the bottom part of the discharge hopper. You can regulate the discharge range by fastening the chain looser or more tightly.



Fastening the chain

4. OPERATIONAL SAFETY



Operational safety

- A safe, efficient and problem-free operation of your wood chipper requires that you and everybody who uses or maintains the wood chipper reads and understands the safety, operation, maintenance and troubleshooting information in this operating manual.
- Personal protective equipment including a safety helmet, safety goggles, safety shoes and gloves are recommended when assembling, positioning, using, changing, maintaining, repairing, removing, cleaning or moving the machine. Avoid long hair, loose clothing or jewelry in the vicinity of moving parts.
- Switch off the engine, stop and switch off the engine, take the key out of the ignition and put it in your pocket, engage the park brake and wait until all moving parts come to a standstill before performing maintenance, changes or repairs or removing obstructions.
- Do not leave the machine running in a closed building to prevent suffocation by exhaust gases.
- Be careful when you put material in the wood chipper. Do not insert metal, bottles, tins, stones, glass or other foreign material in the wood chipper. If material that should not be there ends in the wood chipper, you must stop the machine, switch off the engine, put the ignition key in your pocket and wait until all moving parts have stopped running before you remove any material and/or obstructions. Check the machine for damage or loose parts before resuming your work.
- Never drink alcohol or take medication that may impede your alertness or coordination during the use of this machine. Consult your general practitioner if you take prescription medication.
- Do not allow anybody to hitch a ride on the machine. There is no safe place for passengers.
- Never allow children or unauthorized people to be around the machine or 'work' with it.
- Never reach into the rotor or the openings of the feed hopper while the engine is running. Position the protective covers and guards and secure them in place before starting the engine.
- Do not move or transport the wood chipper while the rotor is turning and the machine is operational.
- Do not exceed the safe driving speed during transport.
- Make sure hydraulic lines and fittings are fixed securely, in good condition and leak-free.
- Keep the workplace clean and free from waste to prevent stumbling. Only work on level ground.
- Do not point the discharge hopper towards people, animals or buildings. The rotor can eject wood chips so fast that injury is caused.



4.1 For the new user or owner

The wood chippers are designed to chip scrap wood, small trees, bushes, branches and other wood waste. The broken-off material is good enough to be composted or to be reused in various ways. The owner or user is responsible for reading this manual and the training of all other operators before they start working with the machine. Strictly follow all safety instructions. Safety is everybody's responsibility. By following the recommended procedures, a safe working environment is offered to all users and bystanders. Untrained users may not work with the machine. Many functions included in this machine are the result of suggestions from customers like you. Carefully read this manual to learn how to use the wood chipper safely and how you can configure it to achieve the maximum benefits. By following the use instructions in combination with a good maintenance program, your wood chipper will offer many years of problem-free service.

4.2 First use

Although there are no use limitations when the wood chipper is used for the first time, we recommend checking the following mechanical parts:

A. After 1 hour of working:

1. Tighten all fastenings and protective covers.
2. Check the condition of the rotor bearings.
3. Check the condition and clearance of the branch breaker, rotor and the stationary blades. Adjust or replace them if required.
4. Check whether any material has become stuck. Remove the stuck material before resuming work.
5. Lubricate all parts that must be greased.

B. After working for 10 hours:

1. Repeat steps 1 to 5 as specified above (Part A).
2. Go to the schedule for normal maintenance.

4.3 Checklist before use

For an efficient and safe operation of the Boxer wood chipper, every user must read and understand the use procedures and all related safety instructions from this chapter. A checklist before use is included for the user. It is important regarding your personal safety and for the continued good mechanical condition of the machine that this checklist is followed.

Before you start to work with the wood chipper and every time thereafter, the following elements must be checked:

1. Lubricate the machine in accordance with the schedule in the Maintenance chapter.
2. Check the rotor, blades and branch breaker. Remove any threads, wires or other materials that are stuck in the machine.
3. Check the condition and clearance of the branch breaker, rotor and stationary blades. Adjust or replace them if required.
4. Check whether all bearings can turn freely. Replace rough or stuck bearings, if any.
5. Make sure all protective covers and guards are where they should be, that they are properly fastened and work as they should do.
6. Check the condition of the curtain in the feed hopper. This must be in a good condition to ensure that wood chips are not ejected from the machine.

4.4 Length of the power take-off

The drive shaft for the power take-off is supplied together with the machine. As a consequence of the various three-point linkages that are currently available, the drive shaft may be too long for most machines or too short for other machines. It is extremely important that the drive shaft can slide in and out freely and does not touch the ground in the work range. If the drive shaft touches the ground, the bearings of both the machine and the power take-off of the tractor will be overloaded and break in the short term.

Follow this procedure to determine the correct length of the drive shaft:

1. Make sure the working area is free from bystanders.
2. Fasten the wood chipper to the tractor but do not yet fasten the drive shaft.
3. Lift the machine until the feed shaft is at the same height as the power take-off of the tractor.
4. Measure the distance between the coupling grooves on the power take-off of the tractor and the feed shaft of the machine.
5. Measure the same length on the pressed in drive shaft.
6. If the length of the pressed-in drive shaft exceeds the length of the machine, the drive shaft must be shortened.

Follow this procedure to shorten the drive shaft:

1. Subtract the length of machine "A" from the length of drive shaft that has not been cut off "B" or (B-A). This length determines how much of the shaft must be cut off.
2. To prevent the shaft from touching the floor, you must add 25 mm from the length to be cut off. This is how you determine the final length to be cut off (C).
3. Use a hacksaw to cut off length (C) from both ends. Cut off both the plastic tubes and the metal cores.
4. Use a file to remove the burrs from the sawed edges.
5. Install the 2 ends of the shaft.
6. Make sure the shaft can slide in and out freely. If this is not the case, you must loosen the 2 parts and check for burrs or chips on the shaft ends. Make sure the shaft can slide in and out freely before installing it.

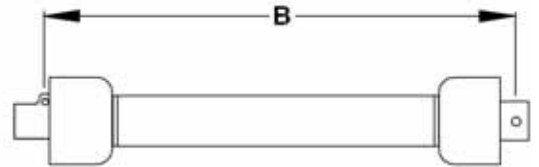
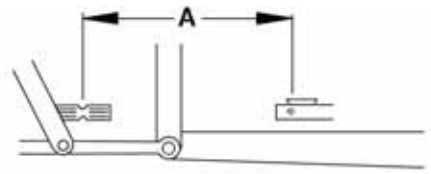

**A: Length of the machine/
B: Length of the power train that
has not been cut off**

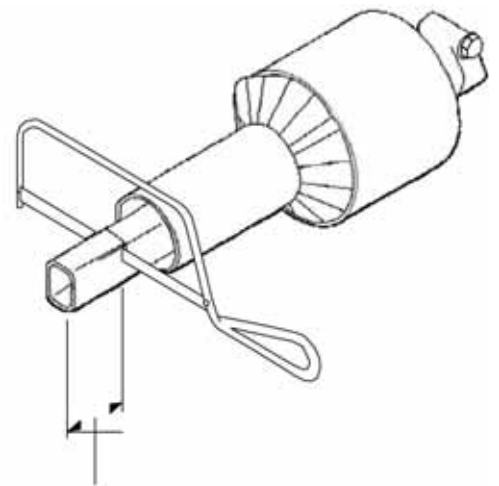

$(B - A) + 1 \text{ inch (25 mm)} = C$ (piece to be cut off)

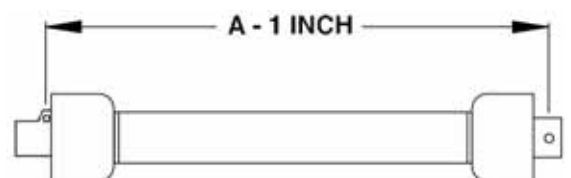

Shortened power train

4.5 Machine commissioning



Operational safety

- A safe, efficient and problem-free operation of your wood chipper requires that you and everybody who uses or maintains the wood chipper reads and understands the safety, operation, maintenance and troubleshooting information in this operating manual.
- Personal protective equipment including a safety helmet, safety goggles, safety shoes and gloves are recommended when assembling, positioning, using, changing, maintaining, repairing, removing, cleaning or moving the machine. Avoid long hair, loose clothing or jewelry in the vicinity of moving parts.
- Switch off the engine, stop and switch off the engine, take the key out of the ignition and put it in your pocket, engage the park brake and wait until all moving parts come to a standstill before performing maintenance, changes or repairs or removing obstructions.
- Do not leave the machine running in a closed building to prevent suffocation by exhaust gases.
- Be careful when you put material in the wood chipper. Do not insert metal, bottles, tins, stones, glass or other foreign material in the wood chipper. If material that should not be there ends in the wood chipper, you must stop the machine, switch off the engine, put the ignition key in your pocket and wait until all moving parts have stopped running before you remove any material and/or obstructions. Check the machine for damage or loose parts before resuming your work.
- Never drink alcohol or take medication that may impede your alertness or coordination during the use of this machine. Consult your general practitioner if you take prescription medication.
- Do not allow anybody to hitch a ride on the machine. There is no safe place for passengers.
- Never allow children or unauthorized people to be around the machine or 'work' with it.
- Never reach into the rotor or the openings of the feed hopper while the engine is running. Position the protective covers and guards and secure them in place before starting the engine.
- Do not move or transport the wood chipper while the rotor is turning and the machine is operational.
- Do not exceed the safe driving speed during transport.
- Make sure hydraulic lines and fittings are fixed securely, in good condition and leak-free.
- Keep the workplace clean and free from waste to prevent stumbling. Only work on level ground.
- Do not point the discharge hopper towards people, animals or buildings. The rotor can eject wood chips so fast that injury is caused.



Although the 3-point wood chipper is easy to use, every operator must read this section to become familiar with the detailed safety and operational procedures. Follow this procedure when you use the machine:

1. Make sure there are no bystanders in the area. Pay especial attention to small children.
2. Read and follow the checklist before use.
3. Fasten the machine to the tractor.
4. Drive to the work area and position the wood chipper at the workplace.
5. Engage the handbrake.
6. Stop the tractor engine.
7. Remove the key from the ignition and keep it on you.
8. Move the hopper down to the work position and fasten it using bolts.
9. Turn the discharge hopper to its work position.

10. Start the machine:

- Start the tractor engine.
- Set the throttle to the lowest stationary speed.
- Allow the power take-off control to run slowly while the engine idles.
- Slowly increase the engine speed to nominal.
- In relation to the manual feed model, you start feeding material into the hopper.
- In relation to the hydraulic feed model:
 - Position the hydraulic lever of the tractor in the locked position.
 - Set the operating lever in the feed position.
 - Begin introducing material into the feed hopper.

11. Stopping:

- Stop introducing material into the feed hopper.
- Switch off the hydraulic supply control or set it to neutral.
- Reduce the engine speed.
- Position the hydraulic lever in the out position.
- Uncouple the power take-off.

Emergency stop

Stop the tractor engine if there is an emergency. Correct the emergency situation before starting the engine and resuming activities.

INSERTING

Hopper with manual introduction

1. Insert wood material slowly into the feed hopper and up to the rotor.
2. Do not force the material into the rotor.
3. Do not push the material too fast into the rotor. Stop or delay if the engine starts to slow down.
4. Do not reach past the curtain in the feed hopper to prevent coming into contact with the rotor blades.
5. Use a stick or branch to push material into the rotor that does not move on its own. Do not run the risk of having your hand trapped in the rotor.

BLADES

The chipper is equipped with 2 types of blades that together chip and cut the wood while it is being fed into the machine.

Rotor blades: The rotor is equipped with 4 blades that are positioned at an angle of 90° from each other to keep the rotor in balance. If one blade is replaced, the opposite blade must also be replaced.



Rotor blades

Stationary blade: Every machine is equipped with a stationary blade that acts as a stop for the moving rotor blades.



Stationary blade



WARNING

The machine is displayed without a cover or rotor cover for illustration purposes only. Do not use the machine without a cover or guard or with an open cover or guard.

Sharpening blades: The rotor and contra-rotating blades must be sharp to ensure the wood chipper works as it should. We recommend disassembling the rotor blades to sharpen them. Always sharpen the blades at an angle of 45°; this guarantees the best cuts with regards to the stationary blade. Make sure the mounting bolts of the blades are tightened with the specified torque when the blades are again installed on the rotor.

The contra-rotating blade has 4 usable corners. If the corner on the side of the rotor blade has rounded, you must disassemble the blade and reposition it at the same position with another corner on the side of the rotor blade. Tighten the mounting bolts using the specified torque.

Clearance: In view of achieving the best performance, a clearance of 0.76 – 1.52 mm between the rotor and the stationary blades is recommended. Set the clearance using the mounting bolts for the stationary blade.

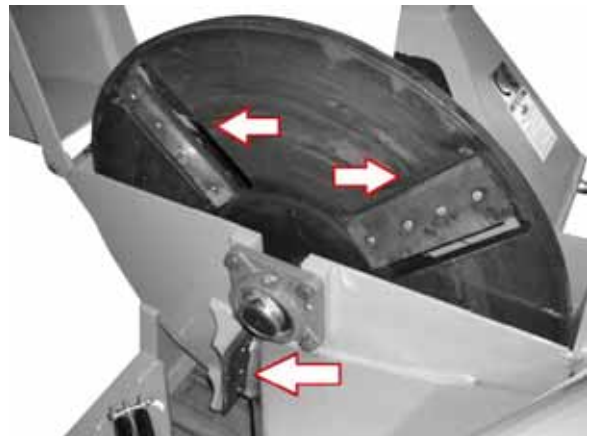

Blades

Branch breaker

Every machine is equipped with a branch breaker that breaks branches or other long material in pieces while being fed through the rotor compartment. Open the rotor housing and check the condition of the branch breaker each week. Also check the branch breaker for material that is stuck when the rotor housing has been opened. Remove the material before closing the cover and resuming work.

Branch breaker: the model with two teeth is being displayed. Some models only have 1 single tooth.



Branch breaker



WARNING

The machine is displayed without a cover or rotor cover for illustration purposes only. Do not use the machine without a cover or guard or with an open cover or guard.

Shear pin

The power train of the power take-off is equipped with a shear pin on the jib to ensure that the drive system is not overloaded. Remove the broken parts from the jib if the pin breaks off and replace it by original BoxerAgri parts. The drive system has been designed to work properly without the shear pin breaking off. If the pin breaks off anyway, it is usually because material is being inserted too fast into the machine or because something hard is trapped in the rotor between the blades. Remove the obstruction, determine the cause of the problem and resolve it before resuming working.



Shear pin



Power train of the power take-off

Removing obstructions

Although the machine has been designed to process various materials without issue, obstructions can sometimes occur. If this happens, you need to follow the following procedure:

1. Make sure bystanders are not close-by and this especially refers to children.
2. Turn the hydraulic feed hopper upside down so that the obstructing material is released.
3. Switch off the engine, put the ignition key in your pocket and wait until all moving parts have come to a standstill before removing the obstruction.
4. Pull the material from the feed hopper. Make sure that all the material has been removed and that nothing is trapped between the feed opening and the rotor.
5. Pull the material from the discharge hopper. Use a stick to release material that is trapped in the discharge hopper. Do not leave anything behind in this hopper.



Feed hopper

Serious obstruction

1. Make sure the engine is completely switched off and that the ignition key is in your pocket to prevent an accidental switching on.
2. Loosen the anchor nuts of the feed hopper and put the feed hopper up. Remove material from the rotor compartment.
3. Clean the discharge part/rotor.
4. Open the rotor cover and clean the housing. Turn the rotor manually to check that nothing is trapped between the rotor and the stationary blades.
5. Close and reposition all parts in their positions that were opened to remove the obstruction. Tighten the fasteners using the specified torque.
6. Check whether everybody is away from the machine before again switching on the engine.
7. Switch on the motor and the power take-off and resume your work.



Discharge hopper

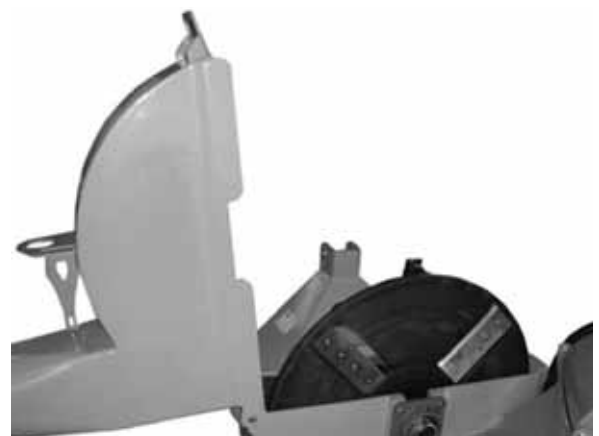

Rotor cover



WARNING

The machine is displayed without a cover or rotor cover for illustration purposes only. Do not use the machine without a cover or guard or with an open cover or guard.

Cleaning

Clean the machine often to prevent the accumulation of dust, chips and dirt on the frame.

Curtains

Every feed hopper has a rubber curtain inside to prevent wood chips and waste from being ejected from the hopper whilst working. Check the condition of the curtain every time you are about to start the machine. Replace the curtain if torn, damaged or missing to limit the risk that material is ejected from the feed hopper to a minimum.

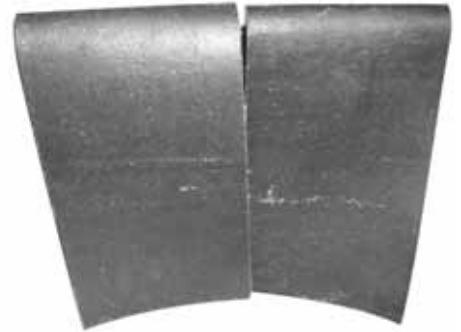

Curtain

Personal protective equipment (PPE)

To prevent injury, everybody must use suitable personal protective equipment whenever they work with the chipper or in the area of the chipper. This list includes the following but is not limited to this:

- Safety shoes with anti-slip soles
- Safety goggles or face shield
- Hearing protection
- Heavy-duty or leather gloves



PPE

4.6 Transport



Transport safety

- Comply with all national and local legislation in relation to the safety and transport of machines on public roads.
- Check whether all lights, reflectors and other lighting facilities are installed and in good working order.
- Do not exceed the safe driving speed during transport. Slow down on rough terrain and when taking bends.
- Do not leave the machine running in a closed building to prevent suffocation by exhaust gases.
- Put the feed hopper up and fasten it before moving or transporting the machine.
- Make sure the machine has been fastened properly to the towing vehicle and that there is a locking pin through the mounting pins.
- Never drink alcohol or take medication that may impede your alertness or coordination during the use of this machine. Consult your general practitioner if you take prescription medication.
- Do not allow anybody to hitch a ride on the machine.
- Be a safe and thoughtful driver. Always give priority to oncoming vehicles under all conditions such as narrow bridges, intersections, etc. Pay careful attention to other road users.

If you want to transport the machine, you must read and observe these instructions:

1. Make sure there are no bystanders in the area. Pay especial attention to small children.
2. Check whether all required lights and reflectors that are required by the traffic authorities are at the correct positions, whether they are clean and whether they work.
3. Make sure the machine has been fastened properly to the tractor with a locking pin through the mounting pins.
4. Do not allow anybody to hitch a ride on the machine.
5. Never exceed the safe driving speed. Slow down when traffic conditions are rough and in bends.
6. Do not drink alcohol if you have to drive.
7. Turn the discharge hopper in the direction of the rotor to make the machine narrower.



Locking

5. SPECIFICATIONS

	HV106
Wood chipper capacity	10 cm
Number of rotor blades	2
Feed system	Manual
Discharge hopper rotation	360°
Discharge hopper height	1.80 m
Weight	196 kg
Required power	18-50 hp

5.1 Torque

CHECK THE TORQUE

The tables below show the correct torques for various bolts and fastening screws. Tighten all bolts in accordance with the torque specified in the table unless stated otherwise. Regularly check whether the bolts are properly fastened based on the table with torques. Replace bolts with bolts of the same strength.

IMPERIAL TORQUES

Bolt diameter "A"	Torque *					
	SAE 2		SAE 5		SAE 8	
	(N·m)	(lb-ft)	(N·m)	(lb-ft)	(N·m)	(lb-ft)
1/4"	8	6	12	9	17	12
5/16"	13	10	25	19	36	27
3/8"	27	20	45	33	63	45
7/16"	41	30	72	53	100	75
1/2"	61	45	110	80	155	115
9/16"	95	60	155	115	220	165
5/8"	128	95	215	160	305	220
3/4"	225	165	390	290	540	400
7/8"	230	170	570	420	880	650
1"	345	225	850	630	1320	970

METRIC TORQUES

Bolt diameter "A"	Torque *			
	8.8		10.9	
	(N·m)	(lb-ft)	(N·m)	(lb-ft)
M3	0.5	0.4	1.8	1.3
M4	3	2.2	4.5	3.3
M5	6	4	9	7
M6	10	7	15	11
M8	25	18	35	26
M10	50	37	70	52
M12	90	66	125	92
M14	140	103	200	48
M16	225	166	310	229
M20	435	321	610	450
M24	750	553	1050	774
M30	1495	1103	2100	1550
M36	2600	1917	3675	2710

The aforementioned torques apply to non-lubricated or non-oiled screw threads and heads unless stated otherwise. Bolts of fastening screws may therefore not be lubricated or oiled unless stated otherwise in this manual. If locking elements are used, the torque must be increased by 5%.

* Torques for bolts and fastening screws are shown through the head markings.

5.2 Torque for hydraulic fittings

Tightening flange pipe fittings*

1. Check the flange and flange seat for damage that may cause leaks.
2. Align the pipe with the fitting before tightening it.
3. Lubricate the connection and fasten the union nut manually until it is in its correct position.
4. Use two wrenches to prevent the pipe(s) from turning. Position one wrench on the coupler; tighten the union nut using the second wrench in accordance with the specified torque.

*The specified torques are based on lubricated couplers as in relation to reinstalling.

Pipe external diameter	Nut size measured along the flat sides	Torque *		Recommended turning to tighten the pipe (after tightening manually)	
		(N·m)	(lb-ft)	(Flat sides)	(Tighten)
3/16	7/16	8	6	1	1/6
1/4	9/16	12	9	1	1/6
5/16	5/8	16	12	1	1/6
3/8	11/16	24	18	1	1/6
1/2	7/8	46	34	1	1/6
5/8	1	62	46	1	1/6
3/4	1-1/4	102	75	3/4	1/8
7/8	1-3/8	122	90	3/4	1/8

6. TROUBLESHOOTING

Problem	Possible cause	Solution
The rotor is not turning.	Obstructed discharge	Fasten it.
	Obstructed rotor	Sharpen or replace the blades.
	Broken off shear pin	Replace the shear pin.
Slow insertion	Blades are blunt.	Sharpen the blades.
	Blade under the incorrect angle: erroneous angle.	Sharpen the blades using the specified angle.
	Obstructed discharge hopper	Remove the obstruction from the discharge hopper.
The chipper asks for too much power or stops.	Obstructed discharge	Remove the obstruction from the discharge hopper.
	Obstructed rotor	Remove the obstruction from the rotor.
	Green material is not being discharged.	Allow the material to dry or alternate between dry and wet material.
	Blunt blades	Sharpen the blades.
Much power needed.	Obstructed rotor	Remove the obstruction from the rotor.
	Blunt blades	Sharpen the blades.
Vibrations during use	Vibration in the power train	Check whether the power train is correctly aligned.
		Check whether the rotor is shaking.
		Check whether the rotor has been correctly installed.

7. CE DECLARATION OF CONFORMITY



Boxer Agriculture Equipment B.V.

A member of de Heus group

Stougjesdijk 153 – 3271KB Mijnsheerenland – Holland

Tel: +31 186 612 333

e-mail : info@boxeragri.nl



EG Conformiteitsverklaring
Volgens machinerichtlijn 2006/42/CE



Konformitätserklärung
Entsprechend der Richtlinie 2006/42/CE



EEC Declaration of Conformity
Conforming to the Directive 2006/42/CE



Déclaration CE de Conformité
Conforme à la directive de la 2006/42/CE

Wij – Wir – We – Nous :

Boxer Agriculture Equipment B.V.
Stougjesdijk 153
3271KB Mijnsheerenland – Holland

Verklaren onder eigen verantwoording dat de machine:

Erklären in alleiniger Verantwortung, daß die machine:

Declare under our own responsibility that the product:

Déclarons sous notre seule responsabilité que le produit:

Machine : Houtversnipperaar / Holzhäcksler /
Broyeur de Bois / Wood chipper

Type/model : HV 106

Seriennummer / Chassis number :

Bouwjaar / Baujahr / Year / Année :

De machine in de verklaring voldoet aan de fundamentele veiligheids- en gezondheidseisen die zijn vastgelegd in de richtlijn van 2006/42 / EG en ter verificatie zijn geraadpleegd UNI: EN 13524: 2004, EN 754. UNI: EN 1553: 2001

Auf dass sich diese Erklärung bezieht, den einschlägigen grundlegenden Sicherheit und Gesundheitsanforderungen EG-Richtlinie 2006/42/CE, UNI:EN 13524:2004, EN 754, UNI:EN 1553:2001 berücksichtigt

To which this certificate applies, conforms to the basic safety and health requirements of EEC Directives 2006/42/CE and following , we have consulted UNI:EN 13524:2004, EN 754. UNI:EN 1553:2001

Faisant l'objet de la déclaration est conforme aux prescriptions fondamentales en matière de sécurité et de santé stipulées dans la Directive de la 2006/42/CE et consultées pour vérification UNI:EN 13524:2004, EN 754. UNI:EN 1553:2001

Mijnsheerenland, 20/08/2019

De gevolmachtigde:

Der Bevollmächtigte:

The legal representative :

Le représentant légal:

