

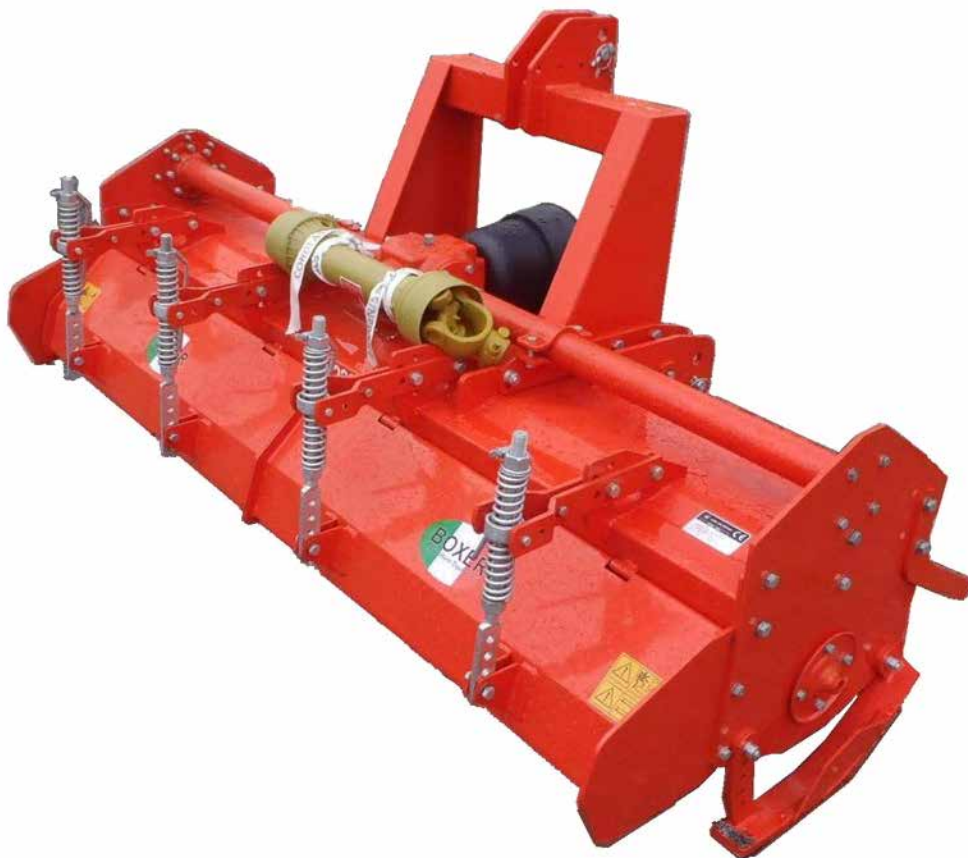

# ROTAVATOR GF USER MANUAL



**P. de Heus en Zonen Greup B.V.**  
Stougjesdijk 153  
3271 KB Mijnsheerenland  
The Netherlands  
Tel: +31 (0) 18 66 12 333  
E-mail: [info@boxeragri.nl](mailto:info@boxeragri.nl)



**ENG | ENGLISH**

**TRANSLATION OF THE ORIGINAL MANUAL**



## CONTENTS

---

<b>1.</b>	<b>GENERAL INFORMATION .....</b>	<b>4</b>
1.1	Symbols .....	4
1.2	Safety pictograms.....	5
<b>2.</b>	<b>SAFETY INSTRUCTIONS .....</b>	<b>7</b>
<b>3.</b>	<b>PUTTING INTO OPERATION/OPERATING INSTRUCTIONS .....</b>	<b>9</b>
<b>4.</b>	<b>STORAGE .....</b>	<b>12</b>
<b>5.</b>	<b>MAINTENANCE, REPAIRS .....</b>	<b>13</b>
5.1	Maintenance .....	14
5.2	Ordering parts .....	15
<b>6.</b>	<b>DISPOSAL AND THE ENVIRONMENT .....</b>	<b>16</b>



---

# 1. GENERAL INFORMATION

## 1.1 Symbols

The safety symbols shown below are used in this booklet.

---



**WARNING**

Tells the user to pay extra attention to specific situations that may put personal safety at risk.

---



**CAUTION**

Highlights situations that may put personal safety at risk.

---







**IMPORTANT**



This highlights generally important information.

---

## 1.2 Safety pictograms

The decals and information on the machine must be followed. Not respecting this may lead to death or serious physical injury. Make sure that all decals are present and visible. If required, contact your closest Boxer dealer.

NO.	SYMBOL	DESCRIPTION
1		Hand injury risk: When the machine is operational, guards must not be removed or opened.
2		Attention: Carefully read the instructions and safety standards before using the machine.
3		Attention: The machine is delivered without any oil.
4		Uses power take-off shaft speed.
5		Prohibited: Do not climb on the machine when it is operational or when the shaft with universal joint is rotating.

NO.	SYMBOL	DESCRIPTION
6		Prohibited: Do not place hands or feet under the machine frame when it is operational.
7		Danger: make sure there is sufficient distance when the machine is operational.

	Working width (cm)	Hp	Cat.	PTO	Weight (kg)	Working depth (cm)	Drive		Blades
							Chain	Gear	
GF 95	90	16 - 20	1	540	115	15	X		4 X 4
GF 115	115	20 - 30	1	540	135	15	X		6 X 4
GF 125	125	25 - 30	1	540	145	15	X		7 X 4
GF 125 T	125	25 - 30	1	540	285	15		X	8 X 4
GF 150	150	25 - 50	1	540	166	15	X		6 X 6
GF 150 T	150	30 - 50	1	540	300	15		X	7 X 6
GF 180 T	180	40 - 75	1 - 2	540	350	15		X	8 X 6
GF 220 T	220	60 - 70	2	540	498	22		X	10 X 6
GF 280 XL	280	90 - 120	2	540	1050	18		X	12 X 6
GF 300 XL	300	130 - 160	2	540	1250	18		X	15 X 6

---

## 2. SAFETY INSTRUCTIONS

It is a fact that the majority of accidents when working and performing maintenance occur because the safety instructions are not followed.

This means that the machine operator must pay careful attention at all times, must put the machine into operation in the correct manner and must prevent that you or others are exposed to unnecessary risks.



### IMPORTANT

If potentially dangerous situations are identified, accidents can be easily prevented!

---

This machine has only been designed for tilling grass and similar activities. Any other use is not permitted. Even if you have operated a comparable machine before, you must read this manual.

The machine operator must make sure before putting it into operation that the tractor and machine meet the general work-related legislation and that traffic regulations can be complied with.

Make sure that the tractor is suitable for the rotavator's technical characteristics.

Personnel who put the machine into operation must be competent and must have the following traits:

**Physical traits:** Good visibility, coordination and options to perform all instructions under safe conditions.

**Mental traits:** The capacity to understand and apply the safety instructions and standards. They must take responsibility with due care and attention for the safety of themselves and other people.

**Training:** They must read this manual and read and study the hazard decals. They must specialize in the use of the maintenance aspects.

### Workwear

Protective equipment must be used when working with and performing maintenance on the machine:

- Workwear: no loose clothing or parts that are hanging loose.
- Safety gloves.
- Helmet for head protection (i.e. hard hat).
- Safety shoes.
- Hearing protection when used for a protracted period.



### IMPORTANT

For your personal protection, keep to the conditions and observe the rules.

---

---

**The following points must be observed when working with and performing maintenance to the machine:**

- Follow all safety instructions including the ones in the manual and the ones that are specified on the machine.
- Operate the machine in a safe manner.
- The machine may only be operated by experienced people who are familiar with the machine.
- Take care and take all precautions with regard to safety.
- Make sure that all safety and protection facilities have always been installed in the intended places.
- Make sure you are not within reach of moving parts.
- Make sure that the engine, power take-off (PTO) shaft and moving parts have stopped working before adjusting, cleaning or lubricating the machine.
- Make sure that nobody is in the danger zone and that everybody is far away from this zone when working with the machine. This applies in particular when working alongside a road close to sports fields, etc.
- Make sure that fields do not have foreign objects or stones.
- Use flashing lights or other safety signs if required.
- Nobody must be on the machine.
- Only use original Boxer parts.
- Pay attention that there are no children around the machine. Also make sure of this when the machine is in storage!
- Always make sure that there are no people in the working area of the machine.
- Never lift people using the machine.
- Do not work on slopes in order to ensure that the machine's evenness is not put at risk.



---

## 3. PUTTING INTO OPERATION/OPERATING INSTRUCTIONS

### Coupling

We recommend carefully reading this manual before starting to work with the machine. All Boxer rotavators are made so that they fit behind any tractor that has a hydraulic coupling system.

Before coupling the rotavator, make sure that the tractor and the machine are positioned on a flat surface and that there are no people in-between the tractor and the machine.

Slowly reverse the tractor and make sure that the arms of the tractor remain aligned with the coupling points of the machine. Next, switch off the tractor's engine and engage the handbrake.

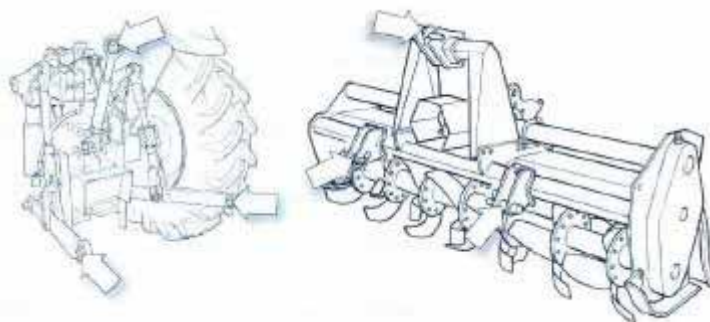

When this has been done, remove pins A from the machine and attach the lift arms of the tractor to the machine using these A pins. Next, attach the top rod of the tractor to the top coupling point of the machine.

Turn the top rod until the top side of the frame is horizontal. Next, block all pins using the relevant check springs.

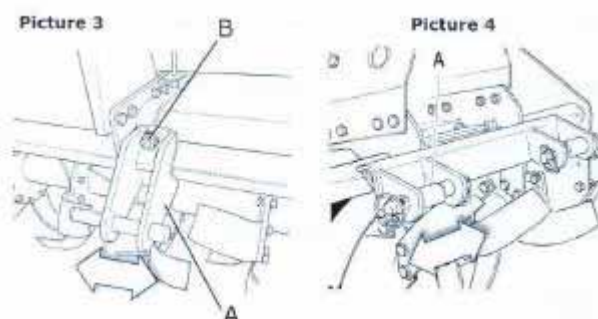

In relation to some Boxer rotavators, you have the option to move the coupling points to obtain a suitable alignment between the tractor and the machine.

In relation to some rotavators, the coupling points can be moved by loosening bolt B (Picture 3) and then moving couplings A. Retighten these bolts properly (see the tightening table for the bolts and nuts).

The suitable alignment for the rotavators can be obtained by moving spacers A (Picture 4).

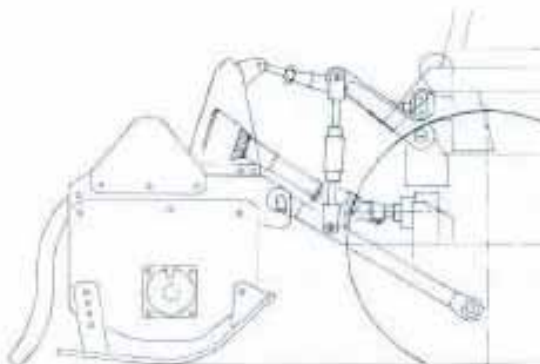



## CAUTION

After having completed the above, we recommend checking whether all bolts and nuts are tightened properly.

---

### Coupling the PTO shaft

Before installing the PTO shaft, it is very important to determine whether the supplied PTO shaft matches the speed and turning direction of the tractor. We therefore recommend that you always carefully read the tractor's manual and also the PTO shaft's manual.

Before continuing, check whether the protection of the outgoing power take-off shaft of the tractor, the machine and the primary shaft are present. In particular, always check whether the protection of the PTO shaft is sufficiently long in the slid-out position.

---



## CAUTION

When the PTO shaft is in its maximum slid-out position, the protections must at least overlap by another 1/3 of their total length (LT) and if it is in its minimum slid-out position, there must still be a clearance of 1-2 cm (0.39 - 1.79"; Picture 5).

---

### Adjustment of the grader

The rear grader can be set with regard to height to achieve an improved grading. Adjust this by loosening chain A (Picture 8) from hook B and reattaching it at the required height.

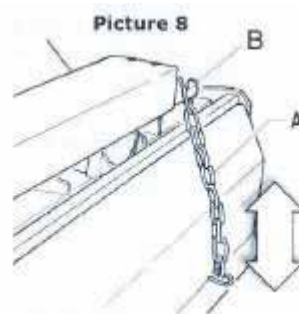

## WARNING

These actions may only be performed when in a field and only after having stopped the engine, having uncoupled the power take-off shaft and having engaged the handbrake. If required, lift the machine from the ground and reposition it on the surface so that nobody can be injured because the machine suddenly falls down.

---

### Setting the depth

The working depth will depend on the position of the trailing shoes. When they are raised, the rotavator will work at a greater depth. If you let them drop, the rotavator will work at a lesser depth. It is key that both trailing shoes are set at the same height with regard to each other.

To change the working depth when tilling, remove bolt A (Picture 6) and change the depth by using one of the other holes (B). Tighten these bolts in accordance with the tightening table for bolts and nuts.

Another method to change the working depth when tilling: loosen bolt A (Picture 7) and slide piece B in the required position. Retighten these bolts in accordance with the tightening table for bolts and nuts.



## **WARNING**

These actions may only be performed when in a field and only after having stopped the engine, having uncoupled the power take-off shaft and having engaged the handbrake. If required, lift the machine from the ground and reposition it on the surface so that nobody can be injured because the machine suddenly falls down.

---

### **Rotor speed**

For the correct speed, refer to the decal on the relevant machine.

### **Chain tension**

Some rotavators are driven by a chain (see the specifications). The tension is provided by an automatic chain tensioner.

### **Working with the machine**

Now that everything is in the required position, the machine is ready to be used. We recommend putting the PTO shaft into operation when the machine is only a few centimeters (an inch or so) above the ground.

If the machine is running, allow it to drop completely.

### **Road transportation**

The machine can be transported by using a tractor or trailer.

Before transporting the machine using a public road, you must make sure that the applicable traffic rules are observed. This, of course, means that tractor lighting and signaling must not be impeded by the machine.

Limit the transportation speed to 30 km/h (18.64 miles per hour) at most if a different maximum permitted speed is not specified on the machine.



---

## 4. STORAGE

If the machine is not to be used for a longer period, we recommend the following:

1. Wash and allow the machine to dry.
2. Check all parts and, if required, replace any damaged ones.
3. Check all bolts and nuts.

Lubricate all moving parts and put the machine on a dry place.

---

## 5. MAINTENANCE, REPAIRS

Maintenance is an essential part to guarantee a long service life and optimum operation of every machine.

A correctly maintained machine will also guarantee greater safety.

The routine maintenance instances specified in this manual are only for information purposes and have been calculated based on normal use. Adjustments are required when used more intensively, when the conditions are more or less dirty and will also depend on the weather conditions.



### CAUTION

Before lubricating grease nipples, they must first be cleaned so that the dirt that is present is not mixed with the grease.

When topping up the oil, we recommend using oil with the same characteristics.

When performing maintenance, it is important that the machine is horizontal and is placed on a stable surface.

Make sure that the machine is always uncoupled from the tractor.

All bolts and nuts must be checked after the first working hour and especially the blade bolts. Also check all safety protections and guards.

---

---

## 5.1 Maintenance

### First routine maintenance: after the first 50 working hours

Replace the oil in the gearbox and check all bolts and nuts.

### Every 8 working hours

Lubricate the rotor using grease nipples A (Picture 20).

Lubricate the PTO shaft.

### Every 50 working hours

Check the oil level of gearbox A (Picture 21).

Check the oil level of sideways drive A (Picture 22).

Check the oil level of the rotor (Picture 23).

If required, top up with SAE 80W90 oil.

Check all bolts and nuts and especially the blade bolts.

### Every 500 hours

Replace the gearbox oil, the oil of the sideways drive and the oil of the rotor.

For these routine maintenance instances, we recommend contacting your closest Boxer dealer.

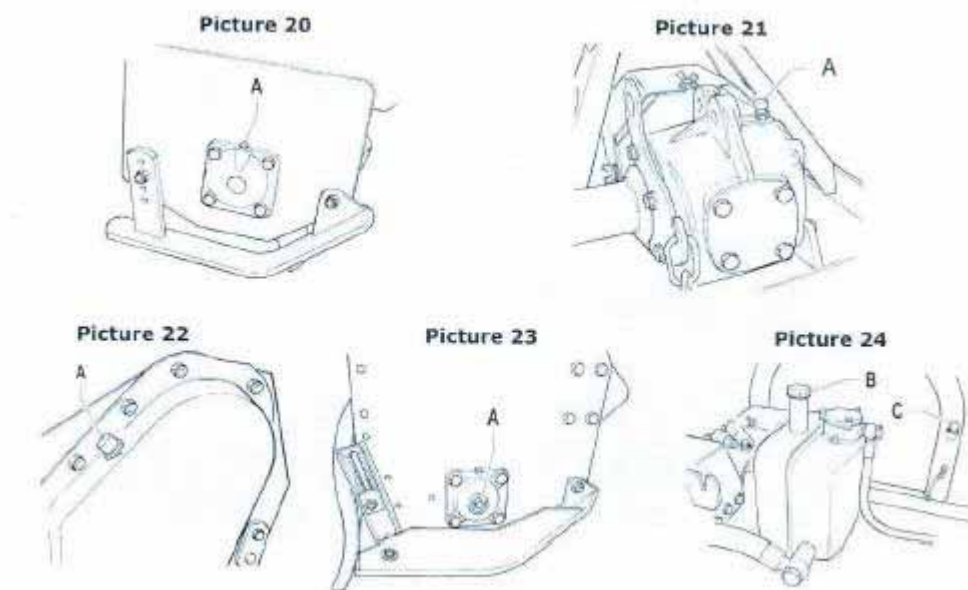

---

## Replacing the blades

To guarantee perfect results, check whether the blades are in good condition and have been tightened correctly using the original bolts and nuts. If required, replace them by the original blades, but make sure that the correct position is retained at all times.

Make sure that blade bolts A (Picture 25) are always on the blade side and the pinion and nut on the flange side so that they cannot be released when used.

When replacing the blades, we recommend to replace blade by blade so that the original blade tooth is always maintained (Picture 26).

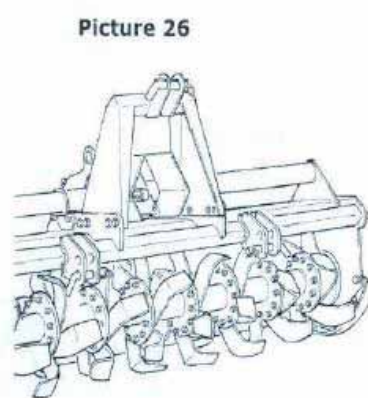
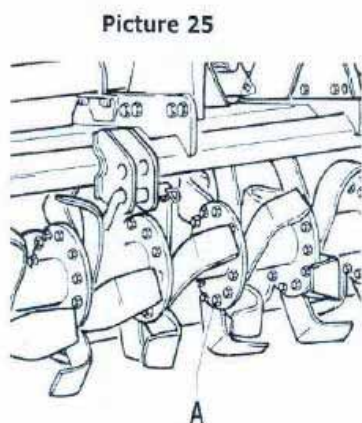

## 5.2 Ordering parts

Consult a parts catalog for ordering parts. Requests must always take place via a Boxer dealer. You need the following information:

- The machine type and width
- Item number (if known)
- The required quantity
- The required mode of transportation in consultation with your dealer.

---

## 6. DISPOSAL AND THE ENVIRONMENT

If the mower is no longer suitable for further use, the hydraulic hoses must be removed and the hydraulic oil must be drained.

Each of the sorted materials must be offered separately to the relevant authorities/companies.